

CONDITIONS FOR USE OF BUILDERS' SKIPS ROAD (SCOTLAND) ACT 1984, SECTION 85 AND 86 (ROAD TRAFFIC REGULATION ACT 1984, SECTION 65)

CONDITIONS APPLICABLE TO THE PERMIT HOLDER

1. The **permit holder** shall ensure that the 'Conditions Applicable to the Skip Owner' are complied with.
2. No skip when standing on the road shall contain any flammable, explosive, noxious or dangerous material or any material which is likely to putrefy, or which otherwise is, or is likely to become a nuisance to users of the road.
3. No skip shall be used in such a way that any of its contents fall onto the road, or that there is an escape of dust from the contents of the skip when standing on the road or in transit.
4. Each skip shall be removed for emptying as soon as practicable and in any case not later than **two working days** after it has been filled.
5. No skip shall remain on the road pursuant to this permission after the period of this permission specified in this document has expired. Should an extension to the period be required, a Renewal must be applied for prior to the expiry of the period.
6. The road where the skip or skips have been deposited shall be left in a clean and tidy condition on the expiration of this permission.
7. The Permit Holder's attention is drawn to clause 7 of the Conditions Applicable to the Skip Owner.
8. If a road is subject to a Traffic Regulation Order then the Police must be notified and their consent obtained to deposit the skip, and a copy of this consent to be forwarded to the Roads Authority manager.
9. The permit shall be shown on demand to any police officer or official of the Roads Authority.
10. The permit holder and the skip owner shall indemnify the Council as Roads Authority for and against all actions, claims, demands, costs, charges, damages, losses and expenses of whatsoever kind or nature which may be brought or made against them or incurred by them in respect of the negligence, omission or default of the permit holder or skip owner or those for whom the permit holder or skip owner are responsible arising in respect of any operation authorised by this permission unless due to the negligence or other breach of legal duty on the part of the Council or if any person for whom the Council are responsible.
11. Any changes to the details on the Skip Permit must be notified immediately, in writing, quoting the Permit Reference Number, to the Roads Authority at the following address:

Email - roadworks@eastlothian.gov.uk

Road Services
East Lothian Council
John Muir House
Haddington
EH41 3HA

CONDITIONS FOR USE OF BUILDERS' SKIPS ROAD (SCOTLAND) ACT 1984, SECTION 85 AND 86 (ROAD TRAFFIC REGULATION ACT 1984, SECTION 65)

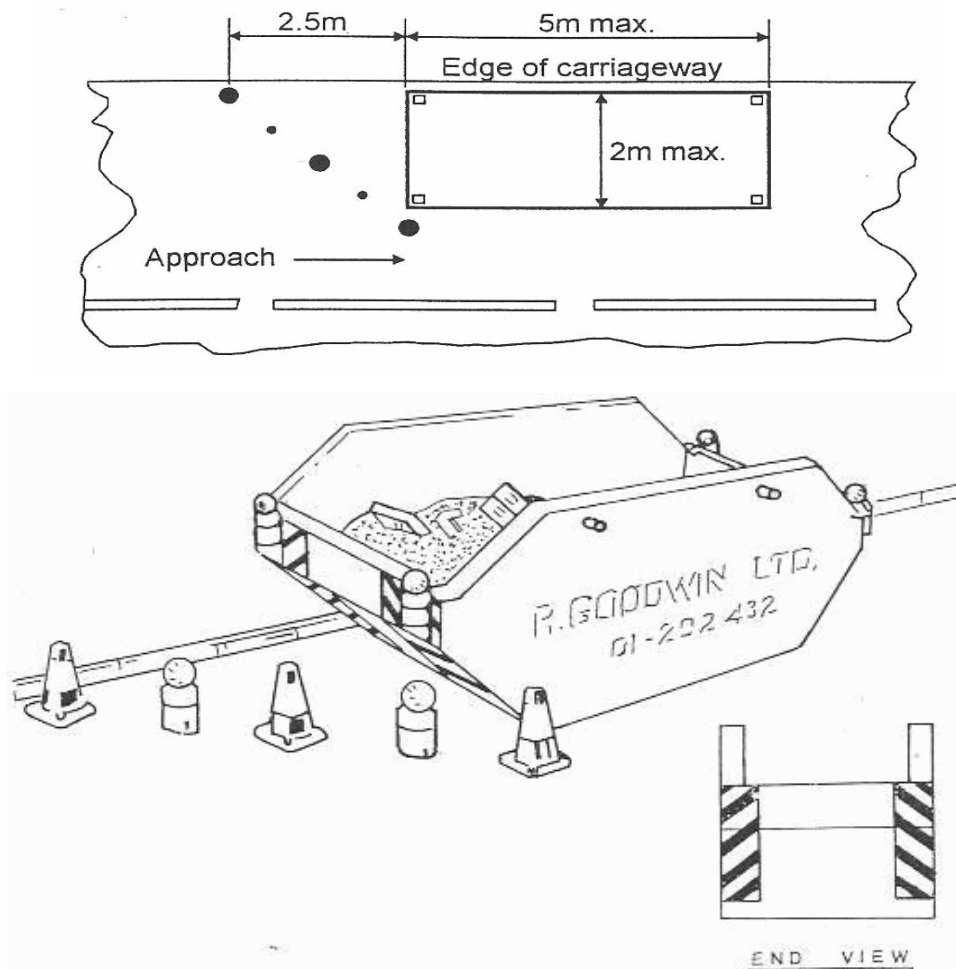

Figure 1. ARRANGEMENTS FOR SITING A SKIP

NOTES:

- i. Dimensions are in metres
- ii. The arrangement of cones and lamps is set out in detail in Condition 6 of the Conditions Applicable To The Skip Owner.

CONDITIONS FOR USE OF BUILDERS' SKIPS ROAD (SCOTLAND) ACT 1984, SECTION 85 AND 86 (ROAD TRAFFIC REGULATION ACT 1984, SECTION 65)

CONDITIONS APPLICABLE TO THE SKIP OWNER

1. Builder's skips for use on the road for the disposal of building materials, rubbish or other things shall comply with the appropriate Motor Vehicles Construction and Use Regulations when carried on a vehicle. Lighting and rear markings of vehicles carrying skips shall comply with the Roads Vehicles Lighting Regulations 1984.
2. Each skip shall be positioned so that its longer sides are parallel to the edge of the carriageway and as near to the edge of the carriageway as is reasonably practicable and so that it does not impede the surface water drainage of the road nor obstruct access to any manhole or the apparatus of any utility company or the Council.
3. In the event that permission is given for more than one skip to be deposited on the road at any one time, the skips shall be positioned as closely as possible to each other, but not so as to obstruct access to any premises unless the consent of the occupier has been obtained.
4. Each skip shall not exceed 5 metres in length by 2 metres in width, and shall be clearly and permanently marked with the owner's name, address and telephone number.
5. The ends of each skip (that is to say, the sides of the skip facing traffic in both directions when the skip is positioned as mentioned in Condition 2 above) shall be painted in a bright colour and there shall be attached, as near to the outer edges of the skip, reflective plates, the composition of which complies with the Builders Skips (Markings) (Scotland) Regulations 1986 No: 646 (S.61). The plates shall consist of broad red fluorescent and yellow reflex reflective diagonal stripes. The painting and the strips of material shall at all times be kept clean.
6. All signs, cones and lighting required to meet the following conditions shall be in good condition and working order.
 - a. Each skip while on the road is to be marked (guarded) and lit in accordance with the requirements of Chapter 8 of the Traffic Signs Manual and the booklet Safety at Street Works and Road Works (a Code of Practice).
 - b. Each skip shall be guarded by at least 3 traffic cones placed on the carriageway in an oblique line on the approach side of the skip. Where 2 or more skips are deposited in a row, so that the distance between adjacent skips does not exceed 2 metres, the row shall be guarded as if it were only one skip.
 - c. At night (that is to say, between half an hour after sunset and half an hour before sunrise) a light shall be placed against or attached to each corner of the skip or the end corners of the row of skips where two or more skips are deposited in a row and the distance between adjacent skips does not exceed 2 metres, and shall be placed between each cone and the next. Lights shall comply with the Traffic Signs Regulations and General Directions (see Figure 1).
7. The owner of the skip shall be responsible for the removal and proper disposal of all materials placed therein, whether by such person or by any other, either with or without authority.
8. The permit holder and the skip owner shall indemnify the Council as Roads Authority for and against all actions, claims, demands, costs, charges, damages, losses and expenses of whatsoever kind or nature which may be brought or made against them or incurred by them in respect of the negligence, omission or default of the permit holder or skip owner or those for whom the permit holder or skip owner are responsible arising in respect of any operation authorised by this permission unless due to the negligence or other breach of legal duty on the part of the Council or if any person for whom the Council are responsible.
9. Section 85 Subsection 3 of the Roads (Scotland) Act 1984 states "An owner of a skip who uses it, or causes or permits it to be used, on a road in contravention of this section commits an offence."